

# ARES

PRIME seating

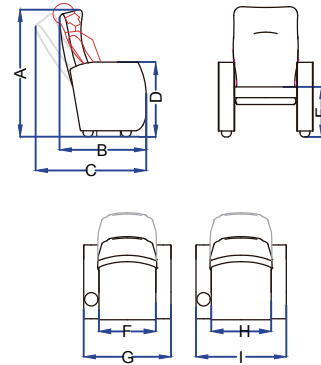

ITEM	POSITION 1		POSITION 2		POSITION 3	
	mm	INCHES	mm	INCHES	mm	INCHES
A	1092	43	1080	42.5	1067	42
B	686	27	737	29	787	31
C	889	35	940	37	991	39
D	635	25	635	25	635	25
E	425	17	425	17	425	17
F	535	21	535	21	535	21
G	793	31	793	31	793	31
H	560	22	560	22	560	22
I	818	32	818	32	818	32

## TECHNICAL SPECS

- Lounge mechanism, cold cured molded polyurethane foam pad with 18-20 kgf of hardness
- High grade steel frame (18 gauge and 1" diameter) for structural integrity, formed with precision CNC benders and robot welded for reliability.
- Upholstered end panels made of wood, reinforced with internal 3mm steel brackets.
- Backrest pan made of injected, high impact polypropylene plastic.
- Plastic cupholder

## OPTIONAL

- Fixed backrest
- Numbering and lettering: plastic or embroidered, by row or by seat.
- Embroidered logos
- Love-seat armrest (retractable center armrest)
- End of row lighting for aisle illumination
- Fixed table: Laminate surface / HPL / Integrated cupholder
- Swivel table: Thermoformed top / Laminate surface / HPL / Tempered glass / Integrated cupholder
- Lineal, radius, flat or slope installations

## WARRANTY

- 5 years warranty for quality defects.